

Development Board ECUcore-5484

Hardware Manual

Edition January 2009

In this manual are descriptions for copyrighted products, which are not explicitly indicated as such. The absence of the trademark (©) symbol does not infer that a product is not protected. Additionally, registered patents and trademarks are similarly not expressly indicated in this manual.

The information in this document has been carefully checked and is believed to be entirely reliable. However, SYS TEC electronic GmbH assumes no responsibility for any inaccuracies. SYS TEC electronic GmbH neither gives any guarantee nor accepts any liability whatsoever for consequential damages resulting from the use of this manual or its associated product. SYS TEC electronic GmbH reserves the right to alter the information contained herein without prior notification and accepts no responsibility for any damages, which might result.

Additionally, SYS TEC electronic GmbH offers no guarantee nor accepts any liability for damages arising from the improper usage or improper installation of the hardware or software. SYS TEC electronic GmbH further reserves the right to alter the layout and/or design of the hardware without prior notification and accepts no liability for doing so.

© Copyright 2009 SYS TEC electronic GmbH. rights – including those of translation, reprint, broadcast, photomechanical or similar reproduction and storage or processing in computer systems, in whole or in part – are reserved. No reproduction may occur without the express written consent from SYS TEC electronic GmbH.

	WORLDWIDE
Address:	SYS TEC electronic GmbH August-Bebel-Str. 29 D-07973 Greiz GERMANY
Ordering Information:	+49 (3661) 6279-0 info@systec-electronic.com
Technical Support:	+49 (3661) 6279-0 support@systec-electronic.com
Fax:	+49 (3661) 62 79 99
Web Site:	http://www.systec-electronic.com

1st Edition January 2009

1	Introduction.....	1
2	Ordering Information and Support.....	3
3	Properties of the Development Board.....	4
	3.1 Overview	4
	3.2 Block Diagram	5
	3.3 Positions of elements.....	6
	3.4 Jumper	7
	3.5 Board connectors.....	9
4	Component Descriptions	14
	4.1 Power Supply	14
	4.2 BDM-Interface	14
	4.3 JTAG-Interface.....	15
	4.4 I/O-Elements	16
	4.5 Ethernet	17
	4.6 USB	17
	4.7 SD-Card.....	18
	4.8 EEPROM.....	18
	4.9 ADC.....	19
	4.10 LED-driver	19
	4.11 CAN.....	19
	4.12 RS232	20

Index of figures and tables

Table 1:	Pinout high density connectors	11
Table 2:	Pinout expansion connectors X300	12
Table 3:	Pinout expansion connectors X301, X302	13
Table 4:	BDM/JTAG connector X403.....	15
Table 5:	JTAG connector X404.....	15
Table 6:	IO-elements connected to ECUcore	16
Table 7:	LED's connected to onboard IC's.....	16
Table 8:	pinout of RJ45-connectors	17
Table 9:	USB-Host connection	18
Table 10:	SD-Card connection.....	18
Table 11:	EEPROM connection.....	18
Table 12:	ADC connection	19
Table 13:	LED driver connection	19
Table 14:	CAN connector pinout.....	20
Table 15:	RS232 connector pinout	20
Table 16:	RS232 connector pinout	20
Table 17:	RS232 connector pinout	21
Figure 1:	Development Board ECUcore-5484.....	4
Figure 2:	Block Diagram Development Board ECUcore-5484	5
Figure 3:	Positions of components	6
Figure 4:	Default Jumper configuration	7
Figure 5:	Jumper pincount.....	7

1 Introduction

The ECUcore-5484 Development Board provides a flexible development platform enabling quick and easy start-up and subsequent programming the Single Board Computer module. The Development Board design allows easy operation of the installed ECUcore in a Communication Networks (LAN, USB, CAN) and allow simple GPIO-Tests by keys and led's. Components for SPI and I²C allow easily testing of these bus-systems. A connection of additional expansion board features various functions that support fast and convenient prototyping and software evaluation.

For the SYSTEC IEC1131-PLC-firmware an additional RUN/STOP/MRES switch is provided on the Development Board as well as one RUN LED and one ERROR LED for indication of the operating mode of the IEC1131-PLC.

This manual describes the function of the development board. Precise specifications for the installed ECUcore or controller populating the ECUcore can be found in the applicable Hardware Manual and controller User's Manual or Data Sheet. No description of the module or microcontroller functions is included in this Hardware Manual, as such functions are not relevant for the basic functioning of the Development Board.

Please refer to the corresponding manuals and documentation for any other board-ic's you may use (USB-Host, Ethernet-Switch, etc.).

Low-active signals are denoted by a „/“ in front of the signal name (i.e. „/RD“). The representation “0” indicates a logical-zero or low-level signal. A “1” is the synonym for a logical one or high-level signal.

2 Ordering Information and Support

Part Number	Version
4002001	Development Board ECUcore-5484

Developmentboard features:

- Socket for ECUcore-5484 (Part.Number: 4002000)
- external power supply 230VAC to 24VDC/1A
- switching regulator 24VDC / 5VDC
- switching regulator 24VDC / 3,3VDC
- 5 keys and 5 led's free usable for development
- one 8position dip-switch
- two hexcode-switches
- one 3position slider switch and 2 led's for using with plc-firmware
- boot- and reset key's and led's
- battery for buffering real-time-clock on ECUcore
- EEPROM 32kiB as SPI example
- potentiometer and ADC as analog input and SPI example
- LED driver as I²C-example
- SD-card socket
- USB2.0-Host with 2 connectors
- Ethernet-Switch with 2 connectors
- Ethernet-connector for onboard PHY on ECUcore
- 2 CAN-interfaces with connectors
- 4 RS232-Interfaces with connectors
- 26pin BDM/JTAG-interface for MCF5484
- 10pin JTAG interface for PLD
- all free usable pins of ECUcore are brought out to expansion connector, 2x 125pol pin contact stripes with user frindly 2,56mm contact spacing

3 Properties of the Development Board

3.1 Overview

The ECUcore-5484 belongs to the SYS TEC's ECUcore family. The ECUcore-5484 integrates all elements of a microcontroller system on a board. The module need's only an external power-supply (3,3V) to operate. The development board was build for accessing all interfaces of ECUcore and rapid development of softwaredrivers and applications. Some special drivers or external controllers are helpfull to interact with the environment (bus-systems, control elements). All interfaces are brought out on standard connectors (RJ45, DSUB).

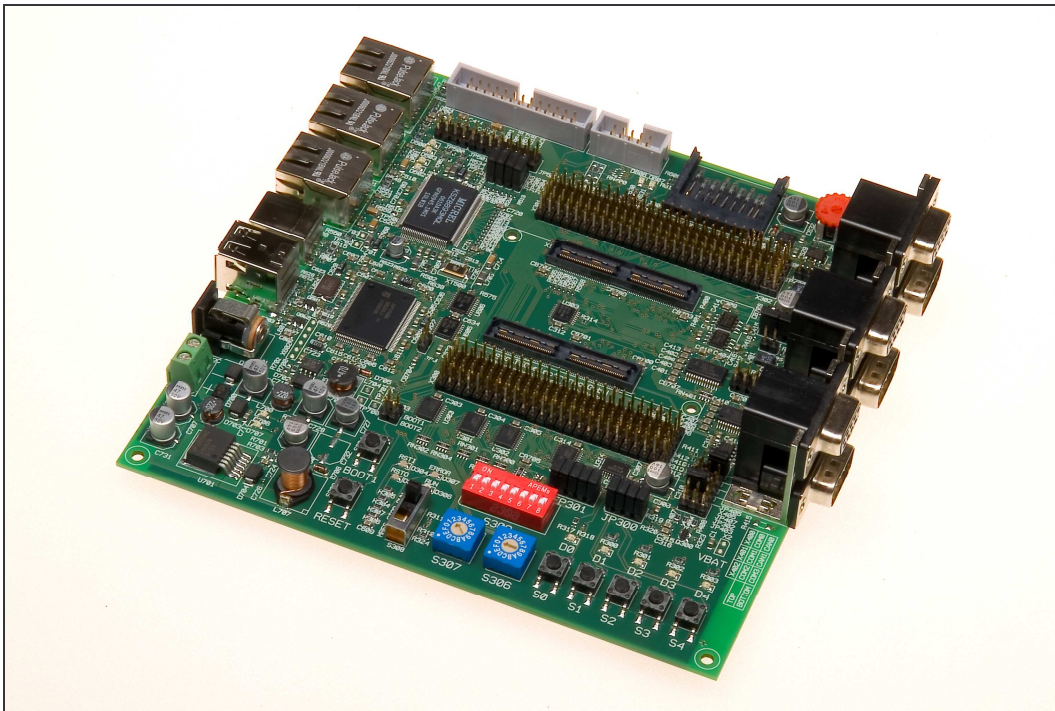

Figure 1: Development Board ECUcore-5484

The dimensions of the board are 160mm x 160mm.

3.2 Block Diagram

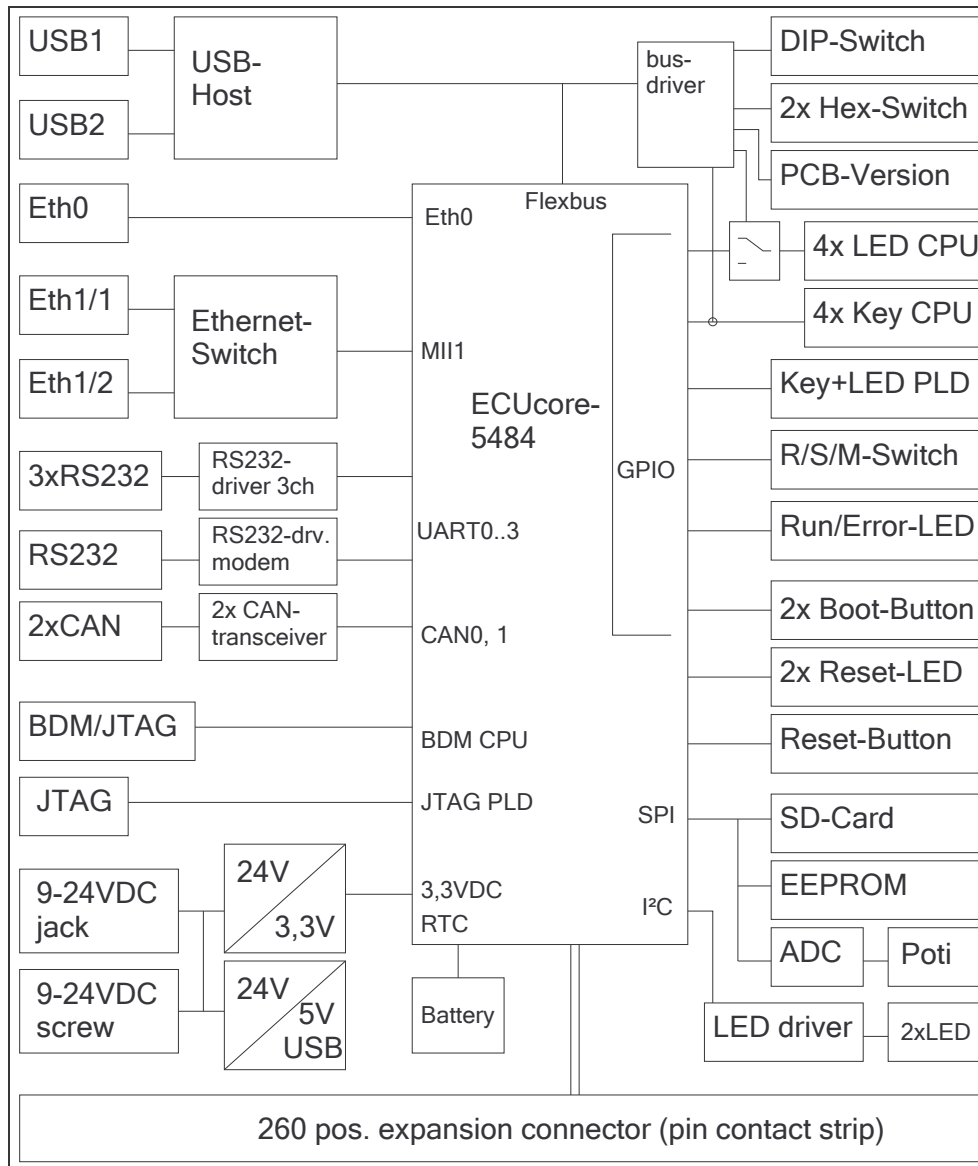

Figure 2: Block Diagram Development Board ECUcore-5484

3.3 Positions of elements

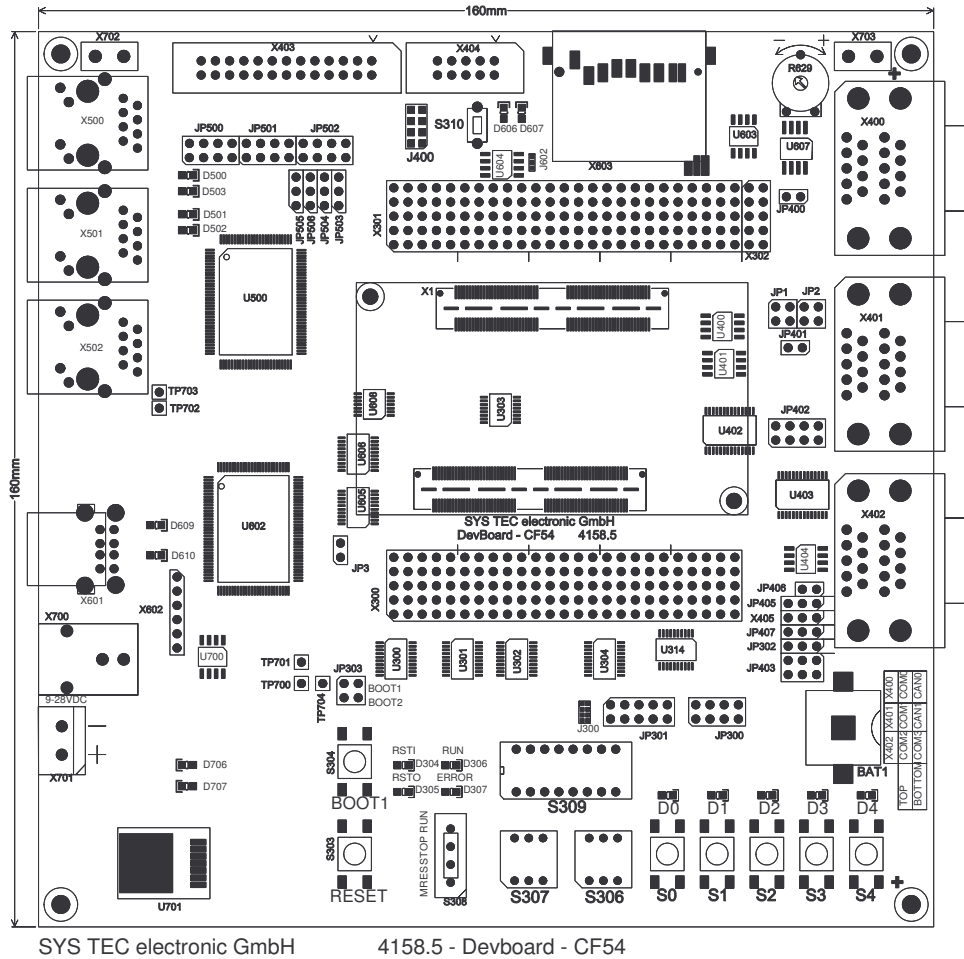

Figure 3: Positions of components

3.4 Jumper

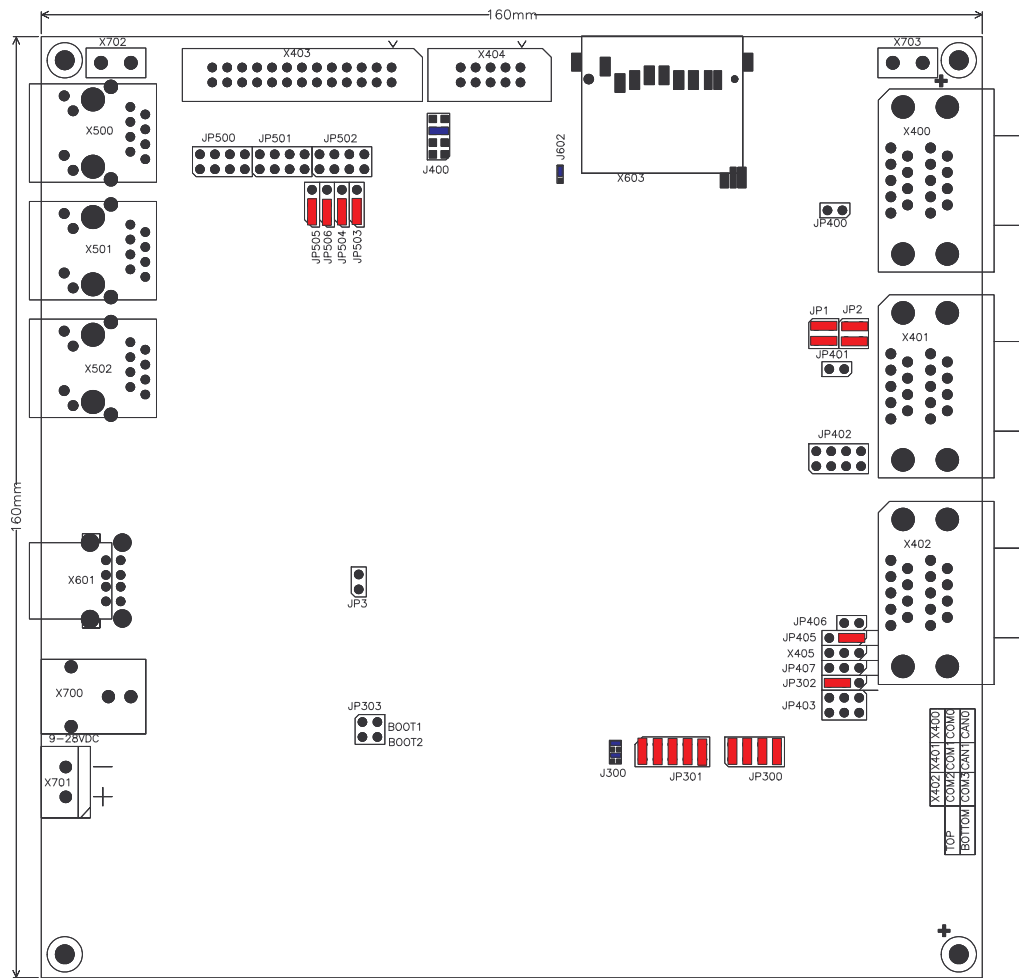

Figure 4: Default Jumper configuration

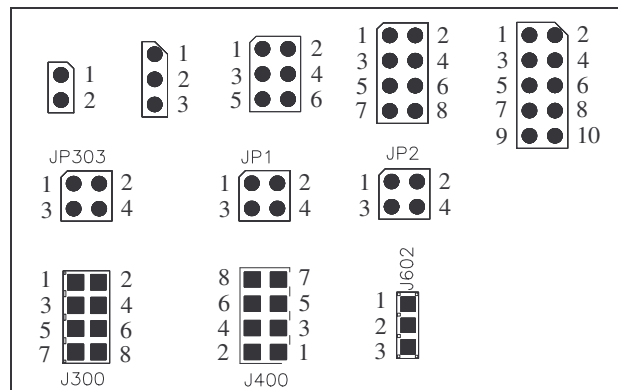

Figure 5: Jumper pincount

Jumper	Signal	Jumper Setting	Function
JP1	CAN_Rx1, TIN2/3	1-2, 3-4 default	Devboard TIN3 is CPU-TIN3, TIN2-Pin is used as CAN_Rx1
		1-3, 2-4	TIN2 is used for TIN3 on Baseboard TIN3-Pin is used as CAN_Rx1
JP2	CAN_Tx1, TOUT2/3	1-2, 3-4 default	Devboard TOUT3 is CPU-TOUT3, TOUT2-Pin is used as CAN_Rx1
		1-3, 2-4	TOUT2 is used for TOUT3 on Baseboard TOUT3-Pin is used as CAN_Rx1
JP3	MTMOD0	1-2 default	BDM-JTAG-Interface in JTAG-Mode
		open	BDM-JTAG-Interface in BDM-Mode
JP300	Buttons on GPIO-Pins	1-2 default	Button S1 on /PCI_BR0
		3-4 default	Button S2 on /PCI_BR1
		5-6 default	Button S3 on TIN1
		7-8 default	Button S4 on TIN3
		any open	Button isn't connect to GPIO
JP302	LED's on GPIO-Pins or Flexbus	1-2	LED's will controlled by Flexbus (AD24-27)
		2-3 default	LED's will controlled by GPIO (PCI_BG1-4)
JP303	BOOT1, 2	1-2	pull /BOOT to GND(parallel to Boot-Button) only if switch1 on ECUcore off !
		3-4	pull PSC_IO3 (BOOT2) to low only if switch2 on ECUcore off !
JP400	CAN0-Termination	1-2	Termination 120R on CAN0 active
JP401	CAN1-Termination	1-2	Termination 120R on CAN1 active
JP402	Modem Handshake	1-2	DCD to TIN3
		3-4	DSR to /PCI_BR4
		5-6	CTS to /PSC3_CTS
		7-8	RIN to /PSC3_RTS
JP403	RS485-Termination	1-2	A485 with 100k pulldown to GND
		3-4	120R between A485 and B485
		5-6	B485 with 100k pullup to 3,3V
JP405	RxD3	1-2	RxD3 on RS232
		2-3	RxD3 on RS485
JP406	TOUT1	1-2	RTS to TOUT1
JP407	TOUT0	1-2	DTR to TOUT0
		2-3	RS485-DE to TOUT0

Jumper	Signal	Jumper Setting	Function
JP500	LAN-Switch-control	1-2	P1FFC with 10k pullup to 3,3V
		3-4	P1DPX with 10k pullup to 3,3V
		5-6	P1SPD with 10k pullup to 3,3V
		7-8	P1FFC with 10k pullup to 3,3V
JP501	LAN-Switch-control	1-2	P2MDIXDIS with 10k pullup to 3,3V
		3-4	P2FFC with 10k pullup to 3,3V
		5-6	P2DPX with 10k pullup to 3,3V
		7-8	P2SPD with 10k pullup to 3,3V
JP502	LAN-Switch-control	1-2	ADVFC with 1k pulldown to GND
		3-4	P2ANEN with 1k pulldown to GND
		5-6	P1ANEN with 1k pulldown to GND
		7-8	P2MDIX with 10k pullup to 3,3V
JP503	LEDSEL0	1-2	LEDSEL0 with 1k pulldown to GND
		2-3	LEDSEL0 with 10k pullup to 3,3V
JP504	LEDSEL1	1-2	LEDSEL1 with 1k pulldown to GND
		2-3	LEDSEL1 with 10k pullup to 3,3V
JP505	Switch Config Mode	1-2	PS0 with 1k pulldown to GND
		2-3	PS0 with 10k pullup to 3,3V
JP506	Switch Config Mode	1-2	PS1 with 1k pulldown to GND
		2-3	PS1 with 10k pullup to 3,3V
J300	PCB-Version	1-2	Bit0 of Version on Flexbus AD16
		3-4	Bit1 of Version on Flexbus AD17
		5-6	Bit2 of Version on Flexbus AD18
		7-8	Bit3 of Version on Flexbus AD19
J400	JTAG	1-2, 3-4, 5-7, 6-8	JTAG on PLD and uC (DaisyChain)
		5-6 default	JTAG only on PLD
J602	A0 of I2C-LED-driver	1-2	A0 pulled down to GND
		2-3	A0 pulled up to 3,3V

3.5 Board connectors

The pitch of the board connectors is about 0,5mm. It is a socket of the Samtec-QSH series and compatible to the QTH-Series. The Type of socket is "QSH-060-01-F-D-A-K".

See figure 3 for position of ECUcore X1 and it's connector-rows. The following table defines the pinout.

Signal	Pin	Pin	Signal	Signal	Pin	Pin	Signal
PSTD0	A01	B01	/RSTI	2,5V_EPHY	C01	D01	GND
PSTD1	A02	B02	/MR	GND	C02	D02	Eth0_TX-
PSTD2	A03	B03	/RSTO	Eth0_RX+	C03	D03	Eth0_TX+
PSTD3	A04	B04	/BKPT	Eth0_RX-	C04	D04	GND
PSTD4	A05	B05	PSTCLK	GND	C05	D05	Link/Act
PSTD5	A06	B06	TCK	Speed	C06	D06	PFEC1H0
PSTD6	A07	B07	DSI	PFEC1L0	C07	D07	PFEC1H1
PSTD7	A08	B08	DSO	PFEC1L1	C08	D08	PFEC1H2
SCL	A09	B09	DSCLK	PFEC1L2	C09	D09	PFEC1H3
SDA	A10	B10	MTMOD0	PFEC1L3	C10	D10	PFEC1H4
PCI_AD0	A11	B11	PCI_AD1	PFEC1L4	C11	D11	PFEC1H5
PCI_AD2	A12	B12	PCI_AD3	PFEC1L5	C12	D12	PFEC1H6
PCI_AD4	A13	B13	PCI_AD5	PFEC1L6	C13	D13	PFEC1H7
PCI_AD6	A14	B14	PCI_AD7	PFEC1L7	C14	D14	E1MDIO
PCI_AD8	A15	B15	PCI_AD9	CAN_Rx0	C15	D15	E1MDC
PCI_AD10	A16	B16	PCI_AD11	CAN_Tx0	C16	D16	USB_D+
PCI_AD12	A17	B17	PCI_AD13	CAN_Rx1	C17	D17	USB_D-
PCI_AD14	A18	B18	PCI_AD15	CAN_Tx1	C18	D18	USB_VBUS
PCI_AD16	A19	B19	PCI_AD17	RxD0	C19	D19	RxD2
PCI_AD18	A20	B20	PCI_AD19	TxD0	C20	D20	TxD2
PCI_AD20	A21	B21	PCI_AD21	RxD1	C21	D21	RxD3
PCI_AD22	A22	B22	PCI_AD23	TxD1	C22	D22	TxD3
PCI_AD24	A23	B23	PCI_AD25	/PSC1_RTS	C23	D23	/PSC3_RTS
PCI_AD26	A24	B24	PCI_AD27	/PSC1_CTS	C24	D24	/PSC3_CTS
PCI_AD28	A25	B25	PCI_AD29	SPI_MTSR	C25	D25	SPI_CLK
PCI_AD30	A26	B26	PCI_AD31	SPI_MRST	C26	D26	/SPI_CS1
PCI_TRDY	A27	B27	/PCI_IRDY	/SPI_CS2	C27	D27	/SPI_CS3
/PCI_CXBE0	A28	B28	PCI_PAR	/SPI_CS4	C28	D28	/SPI_CS5
/PCI_CXBE1	A29	B29	/PCI_PERR	/SPI_CS6	C29	D29	/SPI_CS7
/PCI_CXBE2	A30	B30	/PCI_SERR	/FB_BWE0	C30	D30	/FB_BWE1

Signal	Pin	Pin	Signal	Signal	Pin	Pin	Signal
/PCI_CXBE3	A31	B31	/PCI_DEVSEL	/FB_BWE2	C31	D31	/FB_BWE3
PCI_IDSEL	A32	B32	/PCI_FRAME	/FB_CS2	C32	D32	/FB_CS3
/PCI_STOP	A33	B33	/PCI_RESET	/FB_CS4	C33	D33	/FB_CS5
/PCI_BG0	A34	B34	/PCI_BR0	FB_ALE	C34	D34	/DREQ0
/PCI_BG1	A35	B35	/PCI_BR1	/FB_TA	C35	D35	/BOOT
/PCI_BG2	A36	B36	/PCI_BR2	/DACK0	C36	D36	PFI
/PCI_BG3	A37	B37	/PCI_BR3	/IRQ5	C37	D37	/IRQ6
/PCI_BG4	A38	B38	/PCI_BR4	/IRQ7	C38	D38	TIN0
FB_AD0	A39	B39	FB_AD1	TOUT0	C39	D39	TIN1
FB_AD2	A40	B40	FB_AD3	TOUT1	C40	D40	TIN3
FB_AD4	A41	B41	FB_AD5	TOUT3	C41	D41	PLD_IO0
FB_AD6	A42	B42	FB_AD7	PLD_IO1	C42	D42	PLD_IO2
FB_AD8	A43	B43	FB_AD9	PLD_IO3	C43	D43	PLD_IO4
FB_AD10	A44	B44	FB_AD11	PLD_IO5	C44	D44	PLD_IO6
FB_AD12	A45	B45	FB_AD13	PLD_IO7	C45	D45	PLD_IO8
FB_AD14	A46	B46	FB_AD15	PLD_IO9	C46	D46	PLD_IO10
FB_AD16	A47	B47	FB_AD17	PLD_IO11	C47	D47	PLD_IO12
FB_AD18	A48	B48	FB_AD19	PLD_IO13	C48	D48	PLD_IO14
FB_AD20	A49	B49	FB_AD21	PLD_IO15	C49	D49	PLD_IO16
FB_AD22	A50	B50	FB_AD23	PLD_IO17	C50	D50	PLD_IO18
FB_AD24	A51	B51	FB_AD25	PLD_IO19	C51	D51	PLD_IO20
FB_AD26	A52	B52	FB_AD27	PLD_IO21	C52	D52	PLD_IO22
FB_AD28	A53	B53	FB_AD29	PLD_IO23	C53	D53	PLD_IO24
FB_AD30	A54	B54	FB_AD31	PLD_IO25	C54	D54	PLD_IO26
FB_R/W	A55	B55	/FB_OE	PLD_IO27	C55	D55	PLD_IO28
VBAT	A56	B56	3,3V	PLD_IO29	C56	D56	PLD_IO30
3,3V	A57	B57	3,3V	PLD_IO31	C57	D57	PLD_IO32
3,3V	A58	B58	3,3V	PLD_IO33	C58	D58	PLD_IO34
3,3V	A59	B59	3,3V	PLD_TMS	C59	D59	PLD_TDI
3,3V	A60	B60	3,3V	PLD_TCK	C60	D60	PLD_TDO

Table 1: Pinout high density connectors

Most Signals are brought out of expansion connectors X300 and X301. These are pin contact stripes with standard contact spacing 2,54mm. So you can easily connect extensions for fast development.

X300	A	B	C	D	E
1	/MR	GND	/RSTI	GND	/RSTO
2	SCL	SDA	PCI_AD0	PCI_AD1	PCI_AD2
3	PCI_AD3	GND	PCI_AD4	GND	PCI_AD5
4	PCI_AD6	PCI_AD7	PCI_AD8	PCI_AD9	PCI_AD10
5	PCI_AD11	GND	PCI_AD12	GND	PCI_AD13
6	PCI_AD14	PCI_AD15	PCI_AD16	PCI_AD17	PCI_AD18
7	PCI_AD19	GND	PCI_AD20	GND	PCI_AD21
8	PCI_AD22	PCI_AD23	PCI_AD24	PCI_AD25	PCI_AD26
9	PCI_AD27	GND	PCI_AD28	GND	PCI_AD29
10	PCI_AD30	PCI_AD31	PCI_TRDY	/PCI_IRDY	PCI_PAR
11	/PCI_CXBE0	GND	/PCI_CXBE1	GND	/PCI_CXBE2
12	/PCI_CXBE3	/PCI_PERR	/PCI_SERR	/PCI_DEVSEL	PCI_IDSEL
13	/PCI_FRAME	GND	/PCI_STOP	GND	/PCI_RESET
14	/PCI_BG0	/PCI_BG1	/PCI_BG2	/PCI_BG3	/PCI_BG4
15	/PCI_BR0	GND	/PCI_BR1	GND	/PCI_BR2
16	/PCI_BR3	/PCI_BR4	FB_AD0	FB_AD1	FB_AD2
17	FB_AD3	GND	FB_AD4	GND	FB_AD5
18	FB_AD6	FB_AD7	FB_AD8	FB_AD9	FB_AD10
19	FB_AD11	GND	FB_AD12	GND	FB_AD13
20	FB_AD14	FB_AD15	FB_AD16	FB_AD17	FB_AD18
21	FB_AD19	GND	FB_AD20	GND	FB_AD21
22	FB_AD22	FB_AD23	FB_AD24	FB_AD25	FB_AD26
23	FB_AD27	GND	FB_AD28	GND	FB_AD29
24	FB_AD30	FB_AD31	FB_R/W	/FB_OE	FB_ALE
25	3,3V	GND	3,3V	GND	3,3V

Table 2: Pinout expansion connectors X300

X301	A	B	C	D	E
1	PFEC1L0	GND	PFEC1H0	GND	PFEC1L1
2	PFEC1H1	PFEC1L2	PFEC1H2	PFEC1L3	PFEC1H3
3	PFEC1L4	GND	PFEC1H4	GND	PFEC1L5
4	PFEC1H5	PFEC1L6	PFEC1H6	PFEC1L7	PFEC1H7
5	E1MDIO	GND	E1MDC	GND	USB_D+
6	CAN_Rx0	CAN_Tx0	CAN_Rx1	CAN_Tx1	USB_D-
7	RxD0	GND	TxD0	GND	USB_VBUS
8	RxD1	TxD1	RxD2	TxD2	RxD3
9	/PSC1_RTS	GND	/PSC1_CTS	GND	TxD3
10	/PSC3_RTS	/PSC3_CTS	SPI_MTSR	SPI_MRST	SPI_CLK
11	/SPI_CS1	GND	/SPI_CS2	GND	/SPI_CS3
12	/SPI_CS4	/SPI_CS5	/SPI_CS6	/SPI_CS7	/FB_BWE0
13	/FB_BWE1	GND	/FB_BWE2	GND	/FB_BWE3
14	/FB_CS2	/FB_CS3	/FB_CS4	/FB_CS5	/FB_TA
15	/DREQ0	GND	/DACK0	GND	/BOOT
16	PF1	/IRQ5	/IRQ6	/IRQ7	TIN0
17	TOUT0	GND	TIN1	GND	TOUT1
18	TIN3	TOUT3	PLD_IO0	PLD_IO1	PLD_IO2
19	PLD_IO3	GND	PLD_IO4	GND	PLD_IO5
20	PLD_IO6	PLD_IO7	PLD_IO8	PLD_IO9	PLD_IO10
21	PLD_IO11	GND	PLD_IO12	GND	PLD_IO13
22	PLD_IO14	PLD_IO15	PLD_IO16	PLD_IO17	PLD_IO18
23	PLD_IO19	GND	PLD_IO20	GND	PLD_IO21
24	PLD_IO22	PLD_IO23	PLD_IO24	PLD_IO25	PLD_IO26
25	3,3V	GND	3,3V	GND	3,3V
X302	5	4	3	2	1
A	PLD_IO33	GND	PLD_IO30	PLD_IO29	PLD_IO27
B	PLD_IO34	PLD_IO32	PLD_IO31	GND	PLD_IO28

Table 3: Pinout expansion connectors X301, X302

4 Component Descriptions

4.1 Power Supply

The Developmentboard needs a supply of 9VDC to 24VDC unregulated. Power should be min. 12W to supply module and any peripheral circuits.

External power supply can be connected by Low Voltage Socket X700 or Terminal Block X701.

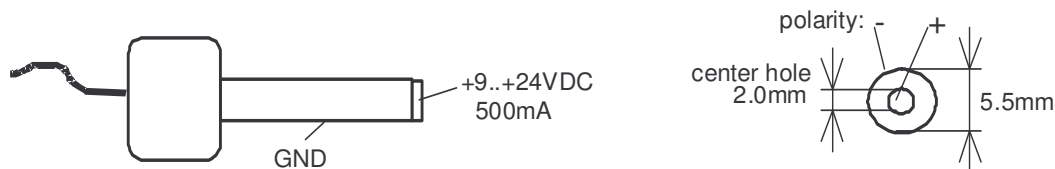

Please ensure that the correct polarity is applied to the terminal block. This is shown on the silkscreen on the PCB next to the terminal block.

From this voltage two switching regulators produce the onboard voltages (5VDC and 3,3VDC).

5VDC only used for USB-Host. 3,3VDC supplies the ECUcore and all other peripheral elements.

4.2 BDM-Interface

The BDM-Interface is for programming and debugging the Coldfire-CPU. It's a pin contact stripes with standard contact spacing 2,54mm.

The Connector-Layout is adjusted for using BDM-Adapter from pemicro (www.pemicro.com) with usb- or parallel interface.

The following table shows the BDM/JTAG layout with pin names.

Signal	Pin	Pin	Signal
not connected	1	2	/BKPT
GND	3	4	DSCLK
GND	5	6	TCK
/RSTI	7	8	DSI
3,3V	9	10	DSO
GND	11	12	PSTD7
PSTD6	13	14	PSTD5
PSTD4	15	16	PSTD3
PSTD2	17	18	PSTD1
PSTD0	19	20	GND
not connected	21	22	not connected
GND	23	24	PSTCLK
not connected	25	26	/FB_TA

Table 4: BDM/JTAG connector X403

With closed Jumper JP3 the MTMOD0-Signal will be pulled high and the JTAG-Mode of Coldfire is active, e.g. for BoundaryScan. Otherwise programming and debugging in BDM-mode is possible.

4.3 JTAG-Interface

A separate JTAG-interface is for programming the PLD. With Jumper J400 it is possible to build a daisy chain with Coldfire and PLD and access both by X404, e.g. for Boundary Scan. The connector is adjusted for Boundary Scan System from Göpel (www.goepel.com), but the Lattice programming interface has a connector with discrete wires for each signal.

Signal	Pin	Pin	Signal
TCK	1	2	GND
TDO	3	4	3,3V
TMS	5	6	not connected
not connected	7	8	not connected
TDI	9	10	GND

Table 5: JTAG connector X404

4.4 I/O-Elements

The developmentboard provides a lot of I/O-elements for rapid development of software and for configuration and using of supplied software. Additional LED's directly connected to onboard periphery, like Power Supply, LAN and USB.

The next table shows the connection of each element at the μ C.

element	connect to	IO on ECUcore	alternative
S0	3,3V	PLD_IO29	
S1	3,3V	/PCI_BR0	Flexbus AD20
S2	3,3V	/PCI_BR1	Flexbus AD21
S3	3,3V	TIN1	Flexbus AD22
S4	3,3V	TIN3	Flexbus AD23
S303 "RESET"	GND	/MR	
S304 "BOOT1"	GND	/BOOT	
S306	3,3V	Flexbus AD0..3	
S307	3,3V	Flexbus AD4..7	
S308	3,3V	PLD_IO32..34	
S309	3,3V	Flexbus AD8..15	
D0	GND	PLD_IO30	
D1	GND	/PCI_BG1	Flexbus AD24
D2	GND	/PCI_BG2	Flexbus AD25
D3	GND	/PCI_BG3	Flexbus AD26
D4	GND	/PCI_BG4	Flexbus AD27
D304 "RSTI"	3,3V	/RSTI	
D305 "RSTO"	3,3V	/RSTO	
D306 "RUN"	3,3V	/PCI_BR2	
D307 "ERROR"	3,3V	/PCI_BR3	
X500 LED green	3,3V	Eth0-PHY Speed	
X500 LED yellow	3,3V	Eth0-PHY Link/Act	

Table 6: IO-elements connected to ECUcore

LED	connect to	Function
D500 (yellow)	3,3V	Ethernet-Switch P1LED1
D501 (yellow)	3,3V	Ethernet-Switch P2LED1
D502 (yellow)	3,3V	Ethernet-Switch P2LED3
D503 (yellow)	3,3V	Ethernet-Switch P1LED3
D606 (green)	3,3V	PC-LED driver
D607 (green)	3,3V	PC-LED driver
D609 (green)	5V	USB-Host /PSW1
D610 (green)	5V	USB-Host /PSW2
D706 (yellow)	5V	5V-Supply
D707 (yellow)	3,3V	3,3V-Supply

Table 7: LED's connected to onboard IC's

4.5 Ethernet

The Coldfire-CPU has two build-in Ethernet-MAC. One Ethernet-PHY (KS8721BL) is on ECUcore at Ethernet0. The Developmentboard provide a RJ45-ModularJack X500 for connecting LAN..

For the second interface a LAN-Switch (micrel KS8893) with build-in PHY provides two RJ45-connections (X501, X502).

Pin	Function
1	TX+
2	TX-
3	RX+
4	TDCT
5	RDCT
6	RX-
7	not connected
8	GND

Table 8: *pinout of RJ45-connectors*

PHY and Switch provides autonegotiation, so standart patch cable can be used, cross-link is not necessary.

4.6 USB

For using USB-Sticks as memory extension or with additional interfaces (e.g. WLAN) a USB-host-controller (NXP ISP1760) is mounted. It servec two USB-A connectors (X601A/B). A third connection is possible on open through hole port X602.

Connector power pins are dirctly supplied by Developmentboard power supply 5VDC and not monitored. No current limitation ist available ! Handle with care !

The supply provides approx. 1A. If the power supply 5VDC drops down (LED D706 switched off) put off the stick and dont't use it again!

The host-controller can be accessed by Flexbus.

Pin	ECUcore-Pin
/CS	/FB_CS2
/RD	/FB_OE
/WR	/FB_BWE0
/IRQ	/IRQ5
/DREQ	/DREQ0
/DACK	/DACK0
/RESET	/RSTI
/SW	pullup to 3,3V
A1	GND
A2..A17	FB_AD2..FB_AD17 with AddressLatch
D0..D31	FB_AD0..FB_AD31

Table 9: USB-Host connection

4.7 SD-Card

SD-Card-socket X603 provides Standard-SD-Cards and MMC-Cards. It is connected to the ECUcore by SPI-Bus.

Pin	ECUcore-Pin
/CS	/SPI_CS2
DI	SPI_MTSR
DO	SPI_MRST
SCLK	SPI_CLK
DETECT	TIN0 (with pulldown)
PROTECT	/PCI_BR0 (with pulldown)
COM	3,3V

Table 10: SD-Card connection

4.8 EEPROM

The 32kiByte EEPROM (Atmel AT25256) can be used for saving configuration or logging data. It will be accessed by SPI-Bus.

Pin	ECUcore-Pin
/CS	/SPI_CS1
SI	SPI_MTSR
SO	SPI_MRST
SCK	SPI_CLK
/HOLD	3,3V
/WP	3,3V

Table 11: EEPROM connection

4.9 ADC

The Analog Digital Converter (TI ADS7822) will be used to getting an analog feature to the plc. Some analog values can be adjusted by Potentiometer R629 and interpreted by software.

Because in this IC only the analog values must be readed, it's not necessary to write parameters (no SI Pin present).

Pin	ECUcore-Pin
/CS	/SPI_CS3
SO	SPI_MRST
SCK	SPI_CLK

Table 12: ADC connection

4.10 LED-driver

For testing I2C-communication an IC is present, witch can drives to LED's D606, D607. The IC (NXP PCA9530) provides blinking or dimming modes for each LED.

Pin	ECUcore-Pin or function
SDA	SDA
SCL	SCL
/RST	/RSTI
A0	GND (by J602=1-2)
LED0	D606
LED1	D607

Table 13: LED driver connection

4.11 CAN

For the two CAN-interfaces of MCF5484 the board provides CAN-transceiver (TI SN65HVD231) and male DSUB9-Connectors (X400A and X401A).

Connector pinnout is compatible to CANopen-Standard.

Pin	function
1,4,5,8,9	not connected
2	CANL
3,6	GND
7	CANH
Shield	not connected

Table 14: CAN connector pinout

CAN-Bus can be terminated by 120R with Jumper JP400 (CAN0) or JP401 (CAN1).

4.12 RS232

The MCF5484 provides 4 UART's. All UART's can be used as RS232-interface by DSUB-connectors on development board.

ECUcore-UART	Name on Devboard	connector	gender	communication signals
UART0	COM0	X400B	female	RxD0, TxD0
UART1	COM1	X401B	female	RxD1, TxD1
UART2	COM2	X402B	female	RxD2, TxD2
UART3	COM3	X402A	male	RxD3, TxD3 + Handshake

Table 15: RS232 connector pinout

UART0..2 are direct accessible. For communication with PC a extensioncable can be used (no null modem required).

UART3 can be used as RS232 modem-interface with null modem cable. The Handshake Signals are provided by GPIO-Pin's of Microcontroller. When handshake used, it can be connected by jumper.

RS232-Interface signal	ECUcore-Pin	Jumper
TXD	TXD3	
RXD	RXD3	JP405 1-2
/RTS	TOUT1	JP406
/DTR	TOUT0	JP407 1-2
/DCD	TIN3	JP402 1-2
/DSR	/PCI_BR4	JP402 3-4
/CTS	/PSC3_CTS	JP402 5-6
/RI	/PSC3_RTS	JP402 7-8

Table 16: RS232 connector pinout

Alternatively UART3 can be used as RS485 interface. The IC U404 (ISL83072E) provides a half duplex interface with A and B wire. X405 is a pin stripe connector for accessing the signals. and GND. Terminations of RS485 can be set by JP403.

Transceive signal	connect to	Jumper
R	RXD3	JP405 2-3
D	TXD3	
DE	TOUT0	JP407 2-3
/RE	GND	
B	X405/1	
A	X405/3	
GND	X405/2	
Termination		
A	100k to GND	JP403 1-2
A	120R to B	JP403 3-4
B	100k to 3,3V	JP403 5-6

Table 17: RS232 connector pinout

Document:	Hardware Manual Devboard ECUcore-5484
Document number:	L-1178e_01, Edition January 2009

How would you improve this manual?

Did you find any mistakes in this manual? page

Submitted by:

Customer number: _____

Name: _____

Company: _____

Address: _____

Return to: SYS TEC electronic GmbH
 August-Bebel-Str. 29
 D-07973 Greiz
 GERMANY
 Fax : +49 (0) 36 61 / 62 79 99

Published by

© SYS TEC electronic GmbH 2008

SYS TEC
ELECTRONIC

Ord. No. L-1178e_01
Printed in Germany